

# Brake Lathes | Accessories

TOOLS FOR THE PROFESSIONAL BRAKE SERVICE SHOP

## Accu-turn offers the Simplest, Fastest, Most Versatile, and Most Efficient operation in the marketplace.

- Accu-turn's arbors and accessories are easily interchangeable, allowing lathes to be readily adapted to a diversity of applications.
- Accu-turn's extra-large, cast-iron, Dovetail Ways are protected by stainless steel telescoping way covers, and are equipped with adjustments for wear.
- Accu-turn Brake Lathes are the most rigid brake lathes available.



\*Shown with 8010 Bronze Adapter Kit and optional 8939 Bench

### 8944L Multi-speed Brake Lathe

- Accu-turn's World Class Brake Lathe design with the added versatility of infinitely adjustable rotor and drum feed speeds between .001"–.010".
- Machines drums, flywheels, and all types of rotors including cross drilled and slotted.
- Three (3) available arbor speeds; 100, 150, 200 provides a whole new level of versatility.
- Increased arbor speed provides for machining times as low as 4 minutes.
- Positive rake tooling yields 'one pass' finish cut every time.
- True machine shop design utilizing Dovetail Ways & Adjustable Gibbs.
- Tapered roller bearing supported spindle designed for maximum longevity.
- Full range of complete accessories to handle virtually any application.

#### Model 8993 Brake Shop Available Includes:

8944L-Brake Lathe, 8939-Deluxed Bench, 040100-Accessory Package, 436054-Truck Set, 434295-Double Taper Radius Cone Set, 434060-Rotor Micrometer, 434287-Drum Wear Gauge

### 8922L Combination Brake Lathe

- The Original Accu-turn World Class Single Pass Lathe that changed the industry.
- Positive rake tooling yields 'one pass' finish cut every time.
- Machines drums, flywheels, and all types of rotors including cross drilled and slotted.
- True machine shop design utilizing Dovetail Ways & Adjustable Gibbs.
- Tapered roller bearing supported spindle designed for maximum longevity.
- Tested and Approved by General Motors for machining rotors to GM's high standards and specifications.
- Full range of accessories available to handle virtually any application.

#### Model 8991 Brake Shop Available Includes:

8922L-Brake Lathe, 8939-Deluxed Bench, 040100-Accessory Package, 436054-Truck Set, 434295-Double Taper Radius Cone Set, 434060-Rotor Micrometer, 434287-Drum Wear Gauge



\*Shown with 8010 Bronze Adapter Kit and optional 8939 Bench

**Accu-turn Brake Lathes exceed ALL manufacturers' tolerances in ...**

- ✓ accuracy
- ✓ parallelism
- ✓ run-out
- ✓ perpendicularity
- ✓ flatness



\*Shown with 8010 Bronze Adapter Kit and optional 8939 Bench

## 8920L High Speed Brake Lathe

- Increased arbor speed provides for machining times as low as 4 minutes.
- Positive rake tooling yields 'one pass' finish cut every time. No need for multiple passes.
- True machine shop design utilizing Dovetail Ways & Adjustable Gibbs.
- Full range of available options to handle virtually any application.

### Model 8990 Brake Shop Available Includes:

8920L-Brake Lathe, 8939-Deluxed Bench, 040100-Accessory Package, 436054-Truck Set, 434295-Double Taper Radius Cone Set, 434060-Rotor Micrometer, 434287-Drum Wear Gauge

## 8989 Heavy Duty Combination Brake Lathe

- Medium and heavy truck lathe with a full 10" drum facing width.
- Shops available with oversized extended arbor and outboard support increasing the lathe capacity to 600 lbs. for rear drum/tire assemblies.
- Two (2) arbor speeds; 52 and 105 for safe truck machining.
- Positive rake tooling yields 'one pass' finish cut every time.
- True machine shop design utilizing Dovetail Ways & Adjustable Gibbs.
- Oversized tapered roller bearing supported spindle designed for maximum longevity.
- Full range of complete Brake Service shop as well as accessories to handle virtually any medium or heavy truck application.
- Includes #8010 Bronze adapter group standard.

### Model 8995 Master Brake Shop Includes:

8989-Heavy-Duty Combination Brake Lathe, 8939A-Deluxe Bench w/Background, 040100-Accessory Package, 434060-Micrometer, Disc Rotor, 436367-Drum Wear Gauge, 434465-Heavy-Duty Adapter Set, 434466 - 1 1/2" Arbor w/Outboard Support Assembly, 434469-Heavy-Duty Boring Bar Assembly, 434472-Step-Down Adapter Set, 1 1/4" to 1", 434661-Double Taper Radius Cone Set, 1 1/2"



\*Shown with optional bench

SPECIFICATIONS	8920L	8922L	8944L	8989
<b>POWER REQUIREMENTS</b>	115 Volt, 50/60 Hertz *220 Volt, 1 Phase Optional	115 Volt 50/60 Hertz *220 Volt, 1 Phase Optional	115 Volt, 50/60 Hertz *220 Volt, 1 Phase Optional	115 Volts, 50/60 Hertz *220 Volt, 1 Phase Optional
<b>ROTOR</b>				
Capacity	4"-24" (102-610 mm)	4"-24" (102-610 mm)	4"-24" (102-610 mm)	4"-24" (102-610 mm)
Maximum Width of Surface	4 1/2" (114 mm)	4 1/2" (114 mm)	4 1/2" (114 mm)	4 1/2" (114 mm)
Maximum Thickness	2 1/4" (57 mm)	2 1/4" (57 mm)	2 1/4" (57 mm)	2 1/4" (57 mm)
<b>DRUM</b>				
Capacity	6"-28" (152-711 mm)	6"-28" (152-711 mm)	6"-28" (152-711 mm)	6"-28" (152-711 mm)
Depth of Cut	6" (152 mm)	6" (152 mm)	6" (152 mm)	10" (254 mm)
<b>FLYWHEEL (FLAT OR STEPPED)</b>				
Capacity	N/A	6"-24" (152-610 mm)	6"-24" (152-610 mm)	6"-24" (152-610 mm)
Friction Surface Capacity	N/A	6" (152 mm)	6" (152 mm)	6" (152 mm)
<b>DRUM/ROTOR/FLYWHEEL MAX. WEIGHT</b>				
On Standard Arbor	150 lbs. (68 kg)	150 lbs. (68 kg)	150 lbs. (68 kg)	150 lbs. (68 kg)
On Heavy Duty Arbor	300 lbs. (136 kg)	300 lbs. (136 kg)	300 lbs. (136 kg)	300 lbs. (136 kg)
On Heavy Duty Arbor w/Outboard Support	N/A	N/A	N/A	600 lbs. (273 kg)
<b>SPINDLE SPEED</b>	180 RPM	105 RPM	100-150-200 RPM	52-105 RPM
<b>FEEDS PER REVOLUTION</b>				
Rotor	0.0046" (0.117 mm)	0.0030" (0.077 mm)	0.001"-0.010" (.026 mm-0.254 mm)	0.0030" (0.077 mm)
Drum	0.0046" (0.117 mm)	0.0046" (0.117 mm)	0.0015"-0.015" (0.039mm-0.381 mm)	0.0046"-0.0092" (0.117 mm-0.234 mm)
<b>MOTOR</b>	1/2 HP (0.350 kW)	1 HP (0.700 kW)	1 HP (0.700 kW)	1 HP (0.700 kW)
<b>WEIGHT</b>				
Net 469 lbs. (213 kg)	469 lbs. (216 kg)	474 lbs. (215 kg)	500 lbs. (227 kg)	525 lbs.
Shipping Gross	560 lbs. (255 kg)	560 lbs. (255 kg)	560 lbs. (255 kg)	560 lbs. (255 kg)

## Gold Adapter Group #8030 for Passenger Cars, Light Through ½ Ton Truck

### #8011 Automotive Kit Includes:

460572 Flange Plate; 4.80"  
460573 Reversible Center Cone; 2.00"–3.98"  
460574 Arbor Spacer; 2.00" (Qty 2)  
460575 Automotive Composite Flange Plate; 5.43"  
460579 Automotive Cone; 1.84"–2.20"  
460580 Automotive Cone; 2.12"–2.47"  
460581 Automotive Cone; 2.37"–2.75"  
460582 Automotive Cone; 2.65"–3.00"  
460583 Automotive Cone; 2.92"–3.30"  
460592 Arbor Spring; 1.92" x 1.00"

### #8012 Light Truck Kit Includes:

460578 Light Truck Composite Plate; 7.25"  
460584 Light Truck Centering Cone; 3.20"–3.57"  
460585 Light Truck Centering Cone; 3.47"–3.85"

### Silencers Includes:

438190 Spring Silencer Band  
438195 Chain Silencer Band  
434296 Clip On Silencer

### Double Taper Adapters Includes:

433711 Double Taper; 2.44"–2.85"  
433710 Double Taper; 2.075"–2.45"  
433709 Double Taper; 1.7"–2.08"  
433708 Double Taper; 1.31"–1.71"  
433963 Double Taper; 1.25"–1.65"



## Silver Adapter Group #8020 for Passenger Cars, Light Trucks

### #8011 Automotive Kit Includes:

460572 Flange Plate; 4.80"  
460573 Reversible Center Cone; 2.00"–3.98"  
460574 Arbor Spacer; 2.00" (Qty 2)  
460575 Automotive Composite Flange Plate; 5.43"  
460579 Automotive Cone; 1.84"–2.20"  
460580 Automotive Cone; 2.12"–2.47"  
460581 Automotive Cone; 2.37"–2.75"  
460582 Automotive Cone; 2.65"–3.00"  
460583 Automotive Cone; 2.92"–3.30"  
460592 Arbor Spring; 1.92" x 1.00"

### Silencers Includes:

438190 Spring Silencer Band  
438195 Chain Silencer Band  
434296 Clip On Silencer

### Double Taper Adapters Includes:

433711 Double Taper; 2.44"–2.85"  
433710 Double Taper; 2.075"–2.45"  
433709 Double Taper; 1.7"–2.08"  
433708 Double Taper; 1.31"–1.71"  
433963 Double Taper; 1.25"–1.65"



## Bronze Adapter Group #8010 for Passenger Cars, Light Trucks

433703 Bell Clamp; 5.56" (Qty 2)  
433704 Bell Clamp; 4.06" (Qty 2)  
433707 Centering Cone; 3"–4"  
433706 Centering Cone; 2.25"–3.25"  
433705 Centering Cone; 1.5"–2.5"  
433712 Spacer; 1"  
433716 Spring

433711 Double Taper; 2.44"–2.85"  
433710 Double Taper; 2.075"–2.45"  
433709 Double Taper; 1.7"–2.08"  
433708 Double Taper; 1.31"–1.71"  
433963 Double Taper; 1.25"–1.65"  
433785 Silencer, Rotor Vented, Large  
433789 Silencer, Non-vented, Small



## Standard Tools (Included with all models)

433701 Arbor 1" (25 mm)  
433713 Arbor Nut  
433702 Drawbar  
436410 Wrench, 1 1/2"  
434559 Wrench, 7/8" (22 mm)  
434558 Wrench, 3/8" (10 mm)  
433750 Twin cutter Assembly with  
with Right Hand Tool Holder (433763)  
and Straight Tool Holder (433286)  
433796 Carbide Inserts, 10 pack  
433764 Left Hand Tool Holder

433782 Drum Silencer  
433774 Spacer, Twin Cutter  
433172 Boring Bar Assembly  
with Right Hand Short Tool Holder (433779)  
433715 Washers (not pictured)  
433633 T-Bolt  
484280 Washer (Qty 2)  
433617 Nut (Qty 2)

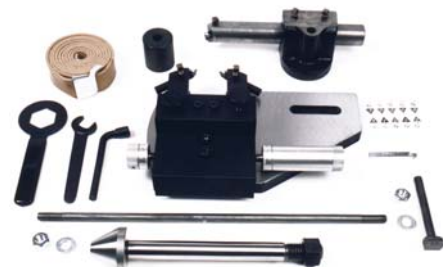



## Platinum Adapter Group #8040 for Passenger Cars, Composite Rotors, and Light Trucks through 1 Ton Trucks

### #8011 Automotive Kit Includes:

460572 Flange Plate; 4.80"  
460573 Reversible Center Cone; 2.00"–3.98"  
460574 Arbor Spacer; 2.00" (Qty 2)  
460575 Automotive Composite Flange Plate; 5.43"  
460579 Automotive Cone; 1.84"–2.20"  
460580 Automotive Cone; 2.12"–2.47"  
460581 Automotive Cone; 2.37"–2.75"  
460582 Automotive Cone; 2.65"–3.00"  
460583 Automotive Cone; 2.92"–3.30"  
460592 Arbor Spring; 1.92" x 1.00"

### #8012 Light Truck Kit Includes:

460578 Light Truck Composite Plate; 7.25"  
460584 Light Truck Centering Cone; 3.20"–3.57"  
460585 Light Truck Centering Cone; 3.47"–3.85"

### #8013 Larger Light Truck Kit Includes:

460576 Large Light Truck Flange Plate; 7.25"  
460577 Large Light Truck Flange Plate; 6.50"  
460586 Light Truck Centering Cone; 3.75"–4.12"  
460587 Light Truck Centering Cone; 4.03"–4.40"  
460588 Light Truck Centering Cone; 4.30"–4.67"  
460589 Light Truck Centering Cone; 4.57"–4.95"  
460590 Light Truck Centering Cone; 4.85"–5.22"  
460591 Light Truck Centering Cone; 5.12"–5.50"

### 434295 Truck Double Taper Set Includes:

434289 Truck Double Taper; 2.840"–3.195"  
434290 Truck Double Taper; 3.190"–3.560"

### Silencers Includes:

438190 Spring Silencer Band  
438195 Chain Silencer Band  
434296 Clip-On Silencer  
434650 Heavy Drum Silencer Band (not pictured)

### Double Taper Adapters Includes:

433711 Double Taper; 2.44"–2.85"  
433710 Double Taper; 2.075"–2.45"  
433709 Double Taper; 1.7"–2.08"  
433708 Double Taper; 1.31"–1.71"  
433963 Double Taper; 1.25"–1.65"

## Optional Accessories

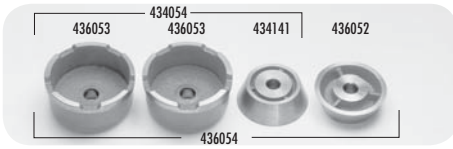

**436054 Light and Medium Truck Set**  
Permits mounting of hubless truck and four-wheel drive drums and rotors through the 350 and 30 series including large bore hubs with center-holes up to 5.55". For use on standard 1" Arbor (433701).

**Specifications:**

- 436053 Bell Clamp 6.88" OD (175 mm)
- 434141 Centering Cone 4.00.0"-5.063" (102-128 mm)
- 436052 Centering Cone 4.500"-5.563" (115-141 mm)

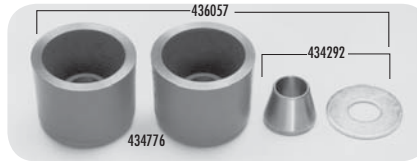

**436057 Small Drum/Flywheel/Hubless Rotor Adapter Set**  
For mounting flywheels, or hubless rotors or drums requiring a bell clamp smaller than the standard 433704. Will also accommodate 433705 standard centering cone.

**Specifications:**

- 434292 1-A Centering Cone Set, 1.250"-1.750" (32-44 mm)
- 434776 Bell Clamp 3.25" OD (83 mm)



**434295 Truck Double Taper Radius Cone Set for 1" Arbor and Brush**  
Designed for mounting larger hubbed drums and rotors standard 1" Arbor (433701). Consists of:

- 434289 Truck Double Taper Adapter #5, 2.840"-3.195" (73-81 mm)
- 434290 Truck Double Taper Adapter #6, 3.190"-3.560" (81-90 mm)

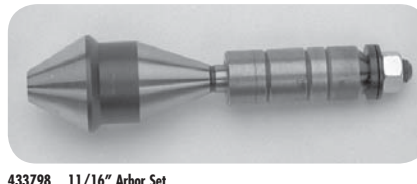

**433798 11/16" Arbor Set**

Handles rotors and drums with center-holes of less than one inch inside diameter. Also handles splined hubbed rotors and drums. Some applications are: Honda, Datsun, Toyota, many imports, and many domestics. (Use 438028 for model 7700)

**Specifications:**

- 434652 Arbor, 11/16" (18 mm) (438028 for model 7700)
- 434476 Spacer, 1" (25 mm)
- 434477 Spacer, 1/2" (13 mm)
- 434478 Arbor Nut
- 434479 Centering Cone
- 433164 Alignment Washers

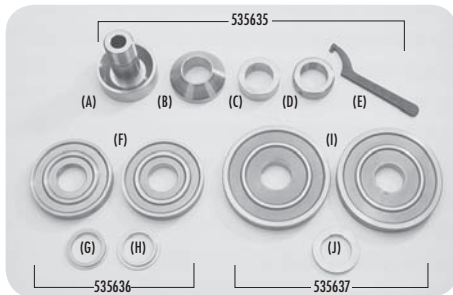

**535620 Universal Hubless and Composite Rotor Adapter Assembly**  
Handles all existing composite rotors and most non-composite rotors. Components can be updated inexpensively for future models. Works on all lathes with 1" arbors. Includes:

**535635 Universal Hubless Rotor Adapter Set**

- Includes:**
- (A) 535622 Hub Base
  - (B) 535623 Taper Cone
  - (C) 535624 Spacer
  - (D) 535625 Nut
  - (E) 535621 Wrench

**535636 Passenger Car Composite Set (Req. 535635)**

- Includes:**
- (F) 535626 Small Plate
  - (G) 535628 Small Centering Plate
  - (H) 535627 Medium Centering Ring
  - (Not Shown) 535631 Pontiac/Chevrolet Centering Ring

**535637 Light Truck Composite Set (Requires 535635)**

- Includes:**
- (I) 535629 Large Plate
  - (J) 535630 Large Centering Ring

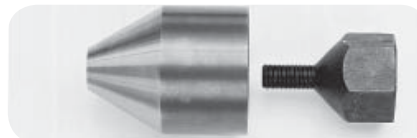

**434775 Small Hole Flywheel Adapter**

For mounting Hyundai and Honda Flywheels, and any other Flywheels with center-holes too small for the 1" Arbor (433701).

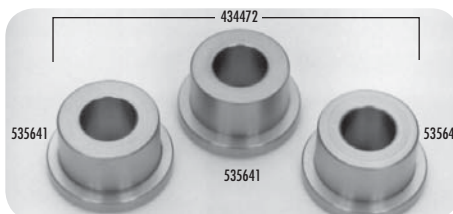

**434472 Step-Down Adapter Set for 1" Arbor**  
Bore: 1 7/8"-to 1". Allows for use of 1 7/8" adapters on standard 1" Arbor (433701). Includes 3-#535641



**Model 3000 Brake Washer**

User-friendly features makes it the most productive brake washer available. Includes 1 qt. T-N-T Cleaner, 2 filters, 1 disposal bag, 1 demonstration video, and 1 Oil Magnet.

**Brake Washer Accessories**

- 7310020 **Supply Kit:** Includes 2 qts. T-N-T, 8 filters w/ disposal bags.
- 7310030 **Deluxe Supply Kit:** Includes 3 qts. T-N-T, 9 filters w/ disposal bags and brush
- 7310018 **Filter:** Box of 12
- 7310028 **Oil Magnet**
- 7310038 **T-N-T Cleaner:** Case of 6 one qt. bottles



**438020 Dust Containment Unit**

Keeps the work area and surrounding inventory free from chips and dust particles. Shown with recommended shop vacuum (436365).

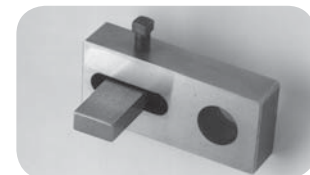

**436271 Freewheeling Rotor and Drum Drive Dog Assembly**

For any type of sealed and/or pressed in bearings such as Ford Probe, Toyota Van, Renault Alliance and others.

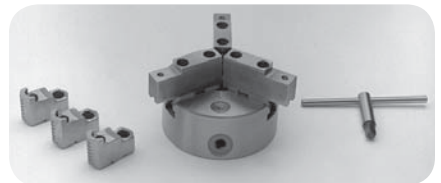

**434770 3-Jaw Chuck Adapter**

Unique versatile adapter which allows mounting to large center-holed flywheels & rotors (5.25" - 7.5") such as VW, Omni, Horizon, etc. Includes two sets of jaws.



**438125 F150 Truck Adapter**

For mounting 2004 and newer 2 WD rotors with pressed in bearings.

# Measuring Devices



**436258 Dial Indicator**  
Vice-grip pliers, flexible-arm dial indicator graduated to 0.001" for measuring runout in rotors and flywheels among other applications. (#433174 Magnetic base dial indicator available)

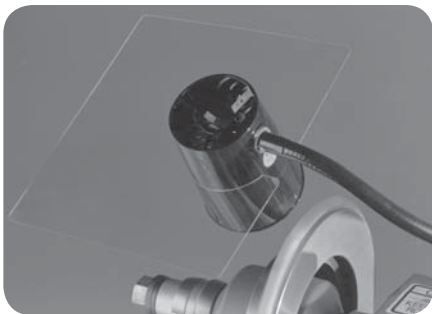

**436056 Lexan Safety Shield**  
For use on all 8900 series ACCU-TURN bench lathe models. Standard with Model 8944.

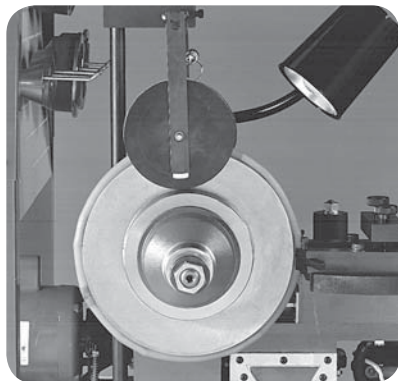

**433179 Non-Directional Rotor Finisher**  
"Insurance policy" for brake jobs. Simultaneously provides non-directional finish to both sides of rotor. Will not affect accuracy. Mounts permanently and conveniently to lathe. U.S. Patent Pending.

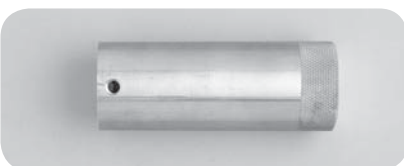

**436272 Twin Cutter Extension Knob**  
Extends right hand twin cutter adjustment knob for easier adjusting.

\*Recommended for all passenger applications



**436229 Digital Rotor Gauge**  
Accurately measures in both inches and metric.



**436230 Digital Drum Gauge**  
Accurately measures in both inches and metric.



- STANDARD**
- (A) 433764 **Left Hand** For rotors and flywheels.
  - (B) 433763 **Right Hand** For rotors, drums, flywheels, and heavy-duty drums.
  - (C) 433779 **Right Hand, Short** For passenger car drums.
  - (D) 434286 **Straight** Recommended for rotors where hub precludes standard tool holders from cutting to square shoulder.
- OPTIONAL BRAZED**
- (E) 434283 **Left Hand** For rotors only.
  - (F) 434059 **Right Hand** For rotors, drums, flywheels, and heavy-duty drums.
  - (G) 434063 **Heavy Duty Right Hand** For heavy duty flywheels and heavy-duty truck drums where heavier tool holder is desired.
- OPTIONAL CURVED**
- For rotors with mounting flanges (i.e. Isuzu Trooper, Toyota Tercel, and Mazda pick-up). Allow for going between mounting flange and machined friction surface.
- (H) 434057 **Left Hand**
  - (I) 434056 **Right Hand**



- CARBIDE INSERTS**
- High quality, positive-rake carbide inserts have the unique capability to cut hard spots on rotors, drums, and flywheels. Each insert has three cutting edges.
- 433795 **Package of 5 Carbide Inserts and 5 Screws**
  - \*433796 **Package of 10 Carbide Inserts and 10 Screws**



**Anti-Chatter Silencer for Vented and Non-Vented Rotors**  
\*434296 **Clip-On Silencer, Optional**



**FOR ROTORS**  
**434060 Micrometer, Disc Brake Rotor**  
Designed to measure wear and thickness variation of disc brake rotors. Also available in metric graduations (434793).

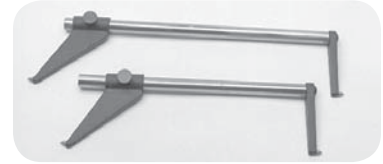

**FOR DRUMS**  
**Drum Wear Limit Gauges**  
Designed to determine whether worn or scored brake drums can be safely machined.

- 434287 Drum Wear Limit Gauge, Passenger Car, 8"-14"** (204-355 mm).
- 436367 Drum Wear Limit Gauge, Passenger Cars Through Trucks, 6"-22"** (150-560 mm).



**Chain Silencer**  
**438195**  
Chain Silencer for non-vented rotors.



**Spring Silencer**  
**438190**  
Spring Silencer for vented rotors.

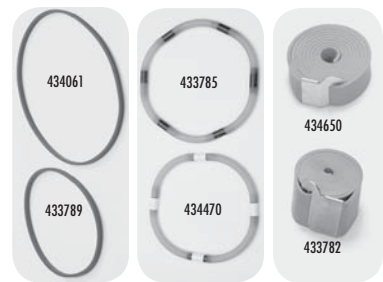

- Silencer Bands for Vented Rotors**
- 434470 Rotor Silencer, Vented, Small, Optional**  
Necessary for most front wheel drive vented.
  - 433785 Rotor Silencer, Vented, Large, Standard**
- Silencer Bands for Non-Vented Rotors**
- 433789 Rotor Silencer, Non-Vented, Small, Standard**
  - 434061 Rotor and Flywheel Silencer, Non-Vented Large, Optional**
- Drum Silencers**
- 433782 Drum Silencer, Passenger Car Width: 1.500" (38 mm), Standard**
  - 434650 Drum Silencer, Heavy-Duty Width: 2.750" (69 mm), Optional**

## Heavy Duty Accessories

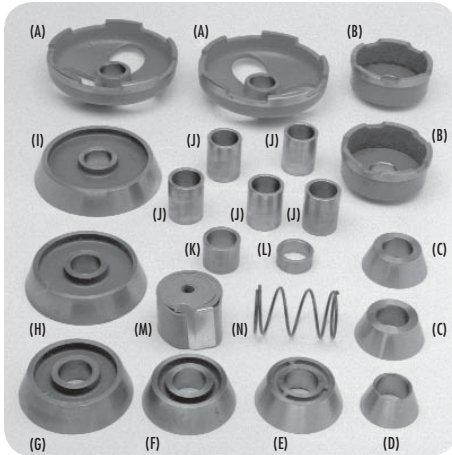

**434465 Heavy-Duty Adapter Set**  
For use with 1 7/8" Heavy-Duty Arbor Set (434055) or with Elongated 1 7/8" Arbor Set with Outboard Support Assembly (434466). For mounting heavy-duty truck hubbed and hubless drums, rotors, and flywheels.

- Consists of:**
- (A) 434649 Bell Clamp, Heavy-Duty, Large 9.75" OD (248 mm)
  - (E) 434648 Bell Clamp, Heavy-Duty, Medium 6.25" OD (159 mm)
  - (C) 434641 Centering Cone, Heavy-Duty, 3.063"-4.250" (78-108 mm)
  - (D) 434643 Centering Cone, Heavy-Duty, 2.188"-3.375" (56-85 mm)
  - (E) 434640 Centering Cone, Heavy-Duty, 4.188"-5.000" (107-127 mm)
  - (F) 434639 Centering Cone, Heavy-Duty, 4.188"-5.375" (107-136 mm)
  - (G) 434644 Centering Cone, Heavy-Duty, 5.313"-6.500" (135-165 mm)
  - (H) 434638 Centering Cone, Heavy-Duty, 6.438"-7.625" (164-193 mm)
  - (I) 434637 Centering Cone, Heavy-Duty, 7.563"-8.750" (193-222 mm)
  - (J) 434645 Spacer, 3" (77 mm)
  - (K) 434646 Spacer, 2" (51 mm)
  - (L) 434647 Spacer, 1" (25 mm)
  - (M) 434650 Drum Silencer, Heavy-Duty
  - (N) 434651 Arbor Spring

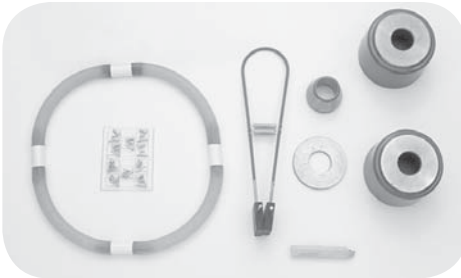

### 040100—ACCESSORY PACKAGE FOR DOMESTIC & FOREIGN PASSENGER CAR, INCLUDES:

- 433796 Carbide Inserts, Pkg. of 10
- 433764 Tool Holder, Left
- 436057 Small Drum/Flywheel/Hubless Rotor Adapter Set
- 434296 Clip-On Anti-Chatter Silencer
- 434470 Rotor Silencer, Small, Vented



Application for 434466: Mounting of dual wheel and tire assemblies.



### 434466 1 7/8" Heavy-Duty Elongated Arbor Set with Outboard Support Assembly

(Pictured on the Model 8989 Heavy-Duty Combination Lathe).  
For drums with dual wheel and tire assemblies. For use with Heavy-Duty Adapter Set (434465).  
Increases weight capacity to 600 lbs. (272 kg).

- Consists of:**
- 434468 Elongated Arbor, 1 7/8" (48 mm)
  - 434653 Arbor Nut
  - 434654 Nut Wrench
  - 434467 Outboard Support Assembly



### 434469 2" Boring Bar, and Boring Bar Holder Assembly

Allows for machining of heavy-duty truck drums and flywheels.

- Consists of:**
- 434656 Boring Bar, 2" (51 mm)
  - 434657 Boring Bar Holder, 2" (51 mm)
  - 433763 Right Hand Tool Holder

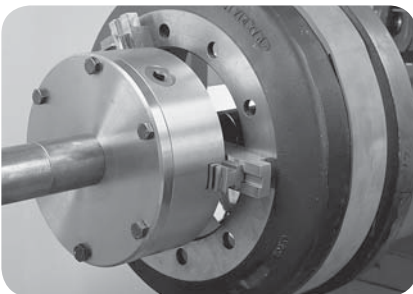

### 436280 Heavy-Duty 3-Jaw Chuck

Used for mounting heavy-duty hubless truck drums and rotors and any other items to be machined which have large center holes (7.75" to 13.5"). 1 7/8" arbor and outboard support are required (434466).

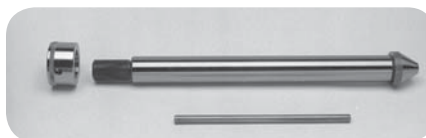

**434055 1 7/8" Heavy-Duty Arbor Set**  
Handles both hubbed and hubless truck drums, rotors and flywheels above 350 series. Requires Heavy-Duty Adapter Set (434465).

- Consists of:**
- 434655 Arbor, 1 7/8" (48 mm)
  - 434653 Arbor, Nut
  - 434654 Nut Wrench



### 434661 Truck Double Taper Radius Cone Set for Heavy-Duty Arbor

Designed for mounting larger hubbed drums and rotors on optional 1 7/8" heavy-duty Arbor (434055, 434466).

- Consists of:**
- 434659 Truck Dbl. Taper Adapter, SM, 2.840"-3.195" (73-81 mm)
  - 434660 Truck Dbl. Taper Adapter, LG, 3.190"-3.560" (81-90 mm)

LOCALLY DISTRIBUTED BY



**Accu Industries, Inc.**

**Headquarters:**  
P.O. Box 15540  
Richmond, VA 23227  
11126 Air Park Road  
Ashland, VA 23005  
804-798-8922  
Fax 804-798-6742  
www.accu-turn.com

**Export Department:**  
Hockman-Lewis Limited  
200 Executive Dr.  
West Orange, NJ 07052  
973-325-3838  
Fax 973-325-7974  
www.hl-ltd.com